

■ UNIVERSAL REMOTE CONTROL



KH 2155

 UNIVERSAL REMOTE CONTROL
 Operating manual

KOMPERNASS GMBH
BURGSTRASSE 21 • D-44867 BOCHUM
www.kompernass.com
ID-NR.: KH2155-01/09-V4



Important safety instructions	2
Device overview	3
First use	4
Unpacking the device / checking the package contents	4
Inserting the batteries	4
Operating elements	5
LCD display	5
Buttons	6
Configuration	9
Setting the time	9
Adjust contrast	9
Background Illumination	10
Child protection system	10
SETUP - System settings	10
Programming the remote control	12
Programming by brand code search	12
Programming by manual code input	13
Programming by automatic code search	14
Learn function	15
Code learn function	16
Clear programmed button	17
Programming Macros	18
Favourites channel	20
Volume control	22
Vol +/-,  (Mute switching)	22
Further volume control functions (except PC)	22
Back to volume control	22
Additional functions	23
All OFF	23
Automatic station redirecting	24
Alternative button allocation in teletext mode	24
Alternative button allocation in PIP mode	25
Faults / Remedies	25
Disposal	26
CE- Conformity	27
Importer	27
Technical data	27
Important Warranty Notices	27

UNIVERSAL REMOTE CONTROL KH2155

Read the operating instructions carefully before using the device for the first time and preserve this booklet for later reference. Hand over the instruction manual to whomsoever you might pass the device on to.

Important safety instructions

Proper use

Children may only operate the remote control under adult supervision.

The universal remote control can replace a maximum of eight remote controls. It can only be used for entertainment electronics with infrared receivers.

The functions of the universal remote correspond to those of the original remote controls. The universal remote control is intended for private use. It is not suitable for commercial use. Any other use is considered improper use. The manufacturer declines to accept responsibility for damage(s) arising from improper use.

There is a danger of injury in the event of improper handling of batteries!

Batteries must be handled with special care. Take note of the following safety instructions:

- Take the batteries out of the battery compartment as soon as they are depleted.
- Do not throw batteries into a fire. Never subject batteries to high temperatures.
- If you will not be using the device for a long period of time, remove the batteries to prevent them from discharging.
- Explosion hazard! Non-rechargeable batteries must never be recharged.
- Do not open the batteries or short-circuit them.
- Battery acid leaking from a battery can cause inflammation of the skin. In the event of contact with the skin, rinse with large amounts of water. If the liquid comes into contact with your eyes, rinse thoroughly with water, do not rub and immediately consult a doctor.
- Always change all batteries at the same time and always use batteries of the same type.
- Keep batteries well away from children. Children can put batteries into their mouths and swallow them. If a battery is swallowed medical assistance must be sought immediately.



Laser

The universal remote control has an infrared diode of laser class 1. A safety system prevents the emission of hazardous laser radiation during use. To prevent eye injuries, do not modify or damage the safety system of the device.

Damage to the device

- If the device is defective, do not attempt to repair it yourself. In case of damage, contact the manufacturer or the manufacturer's service hotline (see Warranty card).
- If liquid escapes from the device or if the device has been otherwise damaged, it must be inspected by the manufacturer or the manufacturer's service hotline. Contact the manufacturer or the manufacturer's service hotline (see Warranty card).

Device overview

- 1 LCD display.
- 2 /ALL OFF button.
- 3 SET button.
- 4 Device buttons
- 5 Illumination button.
- 6 CH +/- buttons.
- 7 VOL +/- buttons.
- 8 Teletext On/Off
- 9 Number buttons.
- 10 RECALL button.
- 11 Button for one or two digit programme numbers.
- 12 Playback button and teletext button.
- 13 Fast text buttons.
- 14 Access the electronic programme guide.
- 15 Arrow buttons.
- 16 EXIT button.
- 17 INFO button.
- 18 OK button.
- 19 MENU button.
- 20 SWAP button.
- 21 PIP button.
- 22 MACRO button.
- 23  Mute switching.
- 24 FAV.CH button.
- 25 AV button.
- 26 Infrared Sender/Receiver.
- 27 Battery compartment cover.

Note:

- The functions described here pertain to the theoretically ideal circumstance that the button structure of the respective original remote control is identical to this universal remote control. This only occurs, however, in rare cases. If, therefore, not all of the original remote control's functions can be reproduced it is not due to a deficiency in the Universal remote control.
- All the brand names used in these instructions or in the accompanying code list are trademarks of the corresponding companies.

First use

Unpacking the device / checking the package contents

⚠ Attention!

Keep the plastic packaging well away from small children. There is a risk of suffocation.

- Unpack the device and accessories.
- Check the package contents,
 - Universal remote control,
 - Operating instructions,
 - Manufacturer list with device code list
- Remove the protective foil from the LCD display ❶.

❶ Note: Transport damage

If you notice any transport damage contact the manufacturer or the manufacturer's Service-Hotline (see warranty card).

Inserting the batteries

⚠ Attention!

The Universal remote control must only be operated with 1.5 Volt batteries (Type AAA, LR03).

Carry out the battery change as quickly as possible. Preset settings will remain saved for approx. 1 minute. If new batteries have not been installed within this time all of the settings will have to be carried out again. The time of day will, however, in any case be deleted.



1. Open battery compartment cover 27 in the direction of the arrows.
2. Insert the batteries as shown in the diagram and close the battery compartment.

The LCD display ❶ is activated as long as batteries are installed. The following diagram shows the LCD display ❶ after the batteries have been installed or changed.



Note:

If no LCD display ❶ is visible check the polarity of the batteries or install new ones.

Operating elements

LCD display

The LCD display ❶ is divided into fields.

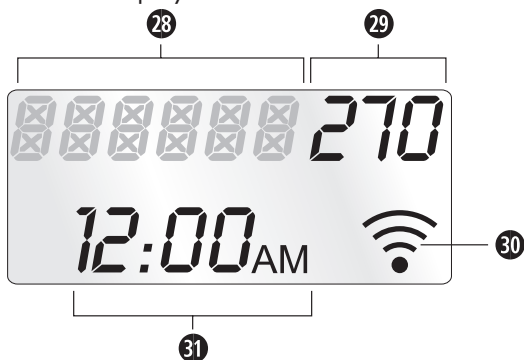

Text field 28

Here is shown the currently selected device, for example DVD, TV or VCR

Code field 29

Here is shown the device code of the currently selected device.

Infrared symbol 30

Every time a button is pressed, with which an infrared signal is to be sent the Infrared symbol illuminates.

Time field 31

Here you can read the time of day.

Standard display:



The standard display of the LCD display ❶ consists of details of the current device, i.e. "TV", the device code and the time of day.

Illumination

If you press the Illumination button LIGHT ❺ with every button press the LCD display ❶ will stay illuminated for 8 seconds. Press the LIGHT button ❺ again to deactivate the illumination function.

Buttons

Note:

All the functions described here can, of course, only be used if they are supported by the device being controlled.

/ALL OFF button ②

ALL OFF



Switch device on/off; press twice within 2 seconds to switch all devices on/off.

SET button ③

SET



Hold down for 3 Seconds to access the **SETUP** menu.

Device buttons ④

The device buttons are used to select which device should be operated.

TV

Television

SAT/CBL

Satellite receiver/cable

AUDIO

Audio device

PC

Computer

VCR

Video recorder

DVD/CD

DVD or CD player

DVR/PVR

Digital/Personal video recorder

AUX

Additional device

Illumination button ⑤

LIGHT



Press the LIGHT ⑤ button to illuminate the display.

CH+/- buttons ⑥

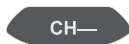

Change the reception channel.

VOL+/- buttons ⑦

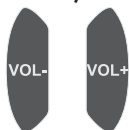

Set volume (**V**olume).

TTX ON/OFF button ⑧



Switch teletext on/off.

Number buttons ⑨



Enter programme and device code numbers.

RECALL button ⑩

RECALL Accesses the last selected programme slot

Button for one/two digit programme numbers ⑪



For two digit programme numbers first press the ⑪ button then via the number buttons ⑨ enter the programme number. When pressed again the display becomes single digit once more.

Playback buttons and teletext function buttons

The playback buttons ⑫ control devices such as DVD/CD players and video recorders:

	Record.
	Stop Playback/Record/Wind
	Rewind
	Start playback
	Stop playback
	Wind forward

In teletext operation the buttons have the following functions:

	Access time
	Cancel page access
	Enlarge page presentation
	Access Index page
	Stop automatic page forwarding for multi page teletexts.
	Mystery button

In addition the CH+/- buttons ⑬ control the following teletext functions:

	Leaf one page forward
	Leaf one page backward

Coloured Fast text buttons ⑭

The coloured fast text buttons open categories in the teletext selection.

GUIDE button ⑮



The GUIDE button accesses the device's electronic programme guide.

Arrow buttons 15

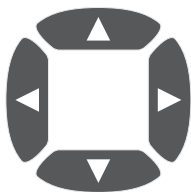

Move up, right, left and down in menus.
For control of the "Picture in Picture" function.

EXIT button 16



Move a level backward in the menu.

INFO button 17



Superimpose programme information.

OK button 18



You can confirm a menu selection with the OK button.

MENU button 19



Access the menu of the controlled device.

SWAP button 20

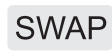

control the A-B repeat function in DVD/CD modes.

To switch between the main and second image in PIP operation.

PIP button 21



to access/end the TV's picture in picture mode.

With SAT/CABLE the PIP button serves as the video format selector.

MACRO button 22

MACRO



The MACRO button 22 followed by a number button 9 1-6, activates the previously saved chain of commands.

Mute switching 23



Switch sound on/off.

FAV.CH button 24

FAV.CH



Accesses your previously programmed favourite station.

AV button 25

AV



Switch to the AV input.

Configuration

Setting the time

The LCD display ❶ shows you the time of day. You set this as follows:

1. Hold down the SET button ❸ for a little longer than 3 seconds.
2. With the ▲ or ▼ button ❶ select "CONFIG" and confirm with the OK button ❸.
3. In the LCD display ❶ appears "TIME SETUP". Confirm with the OK button ❸. The LCD display ❶ now shows "TIME" and the first number of the hour display blinks.
4. With ◀ or ▶ ❶ place the cursor on the position, in which you want to make an entry and press the number buttons ❹ to set the hour and minutes. The switching between AM and PM you undertake with the ▲ or ▼ button ❶. Thereby "AM" stands for "ante meridium" (= morning, 0:00 to 12:00 o'clock) and "PM" stands for "post meridium" (= afternoon, 12:00 to 0:00 o'clock).
5. With the OK button ❸ you save the setting. In the LCD display ❶ appears "SUCCESS" and the previous mode is accessed again. In the event of an error the LCD display ❶ shows "ERROR".
6. To exit this menu press repeatedly the EXIT button ❹ until the standard display appears in the LCD display ❶.

Adjust contrast

You can set the display's contrast as follows:

1. Hold down the SET button ❸ for a little longer than 3 seconds.
2. With the ▲ or ▼ button ❶ select "CONFIG" and confirm with the OK button ❸.
3. With the ▲ or ▼ button ❶ select "CONTRAST" and confirm with the OK button ❸.
4. With the ◀ or ▶ ❶ button you set the contrast (▶ reduces the contrast, ◀ increases the contrast).
Display readout:
0 = highest contrast
15 = lowest contrast
5. With the OK button ❸ you save the desired setting. In the LCD display ❶ appears "SUCCESS" followed by "CONTRAST".
6. To exit this menu press repeatedly the EXIT button ❹ until the standard display appears in the LCD display ❶.

Background Illumination

When the lighting circumstances are poor you can activate the display's background illumination. Bear in mind that this will reduce the lifespan of the batteries.

1. Press once the LIGHT button ⑤. From now on the LCD display ① will illuminate with each button press for approx. 8 seconds.
2. Press this button once more to switch off the LCD display's background illumination.

Child protection system

With the child protection system the channel buttons (CH+, CH-, 0-9) can be locked for individual devices.

1. Hold down the SET button ③ for a little longer than 3 seconds.
2. With the ▲ or ▼ button ⑮ select "CONFIG" and confirm with the OK button ⑱.
3. With the ▲ or ▼ button ⑮ select "KIDS LOCK" and confirm with the OK button ⑱. The LCD display ① shows the current device and always offers the setting "OFF" independent of the current setting.
4. With the ◀ or ▶ button ⑮ select now between "ON" (child protection on) or "OFF" (child protection off).
5. With the OK button ⑱ you save the setting. In the LCD display ① appears "SUCCESS" and then "KIDS LOCK".
6. To exit this menu press repeatedly the EXIT button ⑯ until the standard display appears in the LCD display ①.

SETUP - System settings

In the system settings you undertake the following:

- Programming the remote control to the devices to be controlled
- Setting the time of day, display contrast and child protection
- The "learning" of determined button commands
- Setting up Macros
- Assigning favourites
- etc.

SYSTEM-SETUP overview

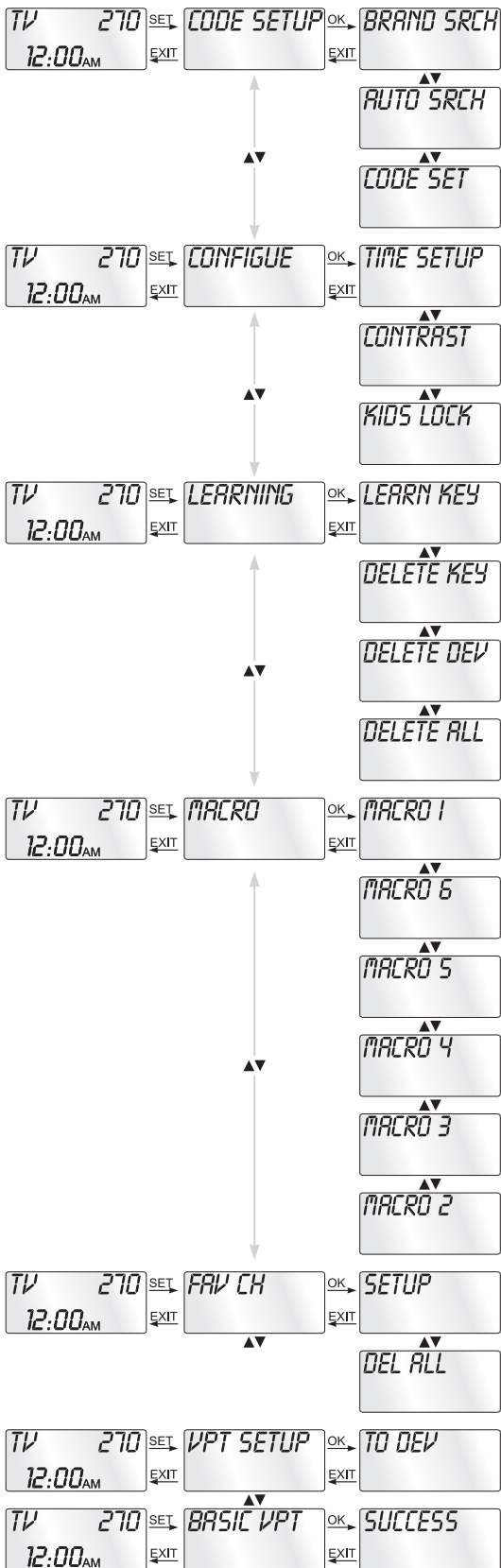

Programming the remote control

3 Programming methods are available for the remote control: Programming by brand code search, by automatic code search and by direct code input (manual).

First you should use the brand code search since this method is the fastest way of programming if your device is itemized in the code list. As second is recommended the direct code input followed by the automatic code search.

Programming by brand code search

With this method you select the brand and code direct via the LCD display ❶.

Observe the following operational references to programme the remote control

1. Press the device button ❹ for the device, on which you want to programme the remote control (except for PC).
2. Hold down the SET button ❸ for a little longer than 3 seconds.
3. In the LCD display ❶ appears "CODE SETUP". Press the OK button ❸. "BRAND SRCH" now appears in the LCD display ❶.
4. Press the OK button ❸. Now appears the alphabetical first brand name from the list of preprogrammed devices.
5. With the ▲ ▼ buttons ❶ select the various brand names.
6. To make access easier you can skip directly to specific letters of the alphabet with the number buttons ❹:
2 => A 3 => D 4 => G 5 => J
6 => M 7 => P 8 => T 9 => W
example: With button number 5 the display skips to the letter "J". The first brand is "JVC"*. If, for example, you own a "Kenwood"* brand device, leaf with the ▼ button downwards until this brand name appears. (* All brand names used here are trademarks of the corresponding manufacturer.)
7. The majority of manufacturers use several different codes for the remote control. You must now ascertain which of the available codes is best suited to your device. The current code is displayed underneath the brand name.
8. Point the remote control to the current device and press the function buttons to test the code (except ▲ ▼ ◀ ▶ ❶, OK ❸, or the number buttons ❹).
9. If most of the buttons function press the OK button ❸ to save the setting. In the LCD display ❶ appears "SUCCESS". Now the mode "BRAND SRCH" appears again.
10. If, however, none or only a few of the buttons function select with the ◀ or ▶ button ❶ the next code and test again as described in step 8.
11. You can end the setting mode with any device button ❹ (except after step 5). With the EXIT button ❶ you will move one level upwards in the menu.

Repeat these operational steps for all devices that you would like to control with the remote control.

Programming by manual code input

In this mode the remote control can be programmed by direct input of a code number. Please extract the necessary code number from the accompanying code list. In the event that the new code is invalid the last valid programmed code will be restored.

1. Hold down the SET button ③ for a little longer than 3 seconds.
2. In the LCD display ① appears "CODE SETUP". Press the OK button ⑱. "BRAND SRCH" now appears in the LCD display ①. Press the ▲ or ▼ button ⑮ until "CODE SET" is shown in the LCD display ①. Then press the OK button ⑱.
3. In the LCD display ① appears the last programmed device and the code used.
4. Press the desired device button ④ (i.e. VCR). The target device now blinks and waits for your confirmation.
5. With the OK button ⑱ confirm the selected device. Now the first digit of the code blinks and waits for your code input.
6. Enter the 3 digit device code with the number buttons and confirm the entry with the OK button ⑱.
7. If the entered code is valid for the selected device type then the code will be saved. In the LCD display ① appears "SUCCESS" and then again "CODE SET". In the event of failure the LCD display ① shows "NOT FOUND" and waits for a new code input. Then you repeat step 6.
8. For many combi-devices you must enter 2 codes from the accompanying list, i.e. one for the TV section and one for the DVD section. If the code of a combi-device (i.e. TV-DVD) is shown in the list as "XXX XXX" then apply the first 3 numbers for the device named first in the device denomination (=TV), and the last 3 numbers for the device named second (=DVD).
9. With the EXIT button ⑲ you can end the CODE SET mode.

8. If the device does not react again carry on switching every 1.5 seconds with the ▼ button 15 to the previous code until the device reacts.
9. Then press the OK button 18 to save the code. The LCD display 1 shows "SUCCESS" and then returns again to the "AUTO SEARCH" mode.
10. Press the EXIT button 16 twice to exit the programming mode.
11. Check to see if the majority of your device's functions can be controlled with the remote control. In the event that a few functions are not working you can start the automatic code search again beginning with step 1.

i Tips:

If the PAUSE II button 12 is pressed during the automatic code search the code search stops. Pressing on the PAUSE II button 12 again allows the device to take up the search once more.

1. During an active code search all buttons except OK 18, PAUSE II 12, ▼, ▲ 15 and EXIT 16 will be ignored.
2. If the EXIT button 16 is pressed during the code search the search will stop and the "AUTO SRCH" status is again accessed without the code being saved.
3. Should the correct code be found, however the device's original remote control did not have a POWER button then it is possible that the device cannot be switched on or off remotely. Then try the buttons ► 15, CH + 6 or MUTE 23.
4. If the automatic search has reached the end of the code list it stops there. Then press the EXIT button 16 to return to the "AUTO SRCH" mode and start again with step 4.
5. If you want to programme an AUX device by automatic code search the device type must first be defined by direct code input. After which you carry out the automatic code search from step 5.

Learn function

The Universal remote control (URC) can learn and save button signals of an original remote control. If the URC does not work after applying the programming methods already described or cannot carry out all commands please attempt to teach the URC with the help of the original remote control.

- Use new batteries for the URC and the original remote control.
- Maintain a distance of at least one metre from other light sources. The light sources could disrupt the infrared transmission.
- Place the URC and the original remote control at a distance of 25 to 55 mm from each other on an even surface so that the Infrared diodes 26 are facing each other.

i Tips:

1. Do not use the following buttons for the learn function: all device buttons ④, LIGHT ⑤, MACRO ②②, FAV.CH ②④, ⑫, EXIT ⑩⑥.
2. When teaching please do not release the button of the original remote control until "SUCCESS" or "FAILED" appears in the LCD display ①.
3. If whilst teaching when the display is showing "WAITING" still no button on the original remote control is pressed after 25 seconds the LCD display ① shows "FAILED" followed by "SELECT KEY".
4. If the memory is full the LCD display ① shows "MEM FULL" and the learn mode will end.
5. Whilst the LCD display ① is showing "WAITING" in the learn mode the mode can only be ended with the EXIT button ⑩⑥.
6. During the learn mode or when the taught buttons are deleted the current mode can be exited with any button (except when "WAITING" is showing).
7. With the EXIT button ⑩⑥ you return to the previous status.

Code learn function

1. Press the desired device button ④.
2. Hold down the SET button ③ for a little longer than 3 seconds.
3. With the ▲ or ▼ button ⑮ select the menu "LEARNING" and then press the OK button ⑰⑧.
4. In the LCD display ① appears "LEARN KEY". Then press the OK button ⑰⑧. In the LCD display ① appears "SELECT KEY".
5. First press the button on the URC that is to be taught. In the LCD display ① appears "WAITING". The URC now waits for the Infrared signal from the original remote control.
6. Point the Infrared sensors ⑳⑥ of both remote controls towards each other.
7. Now hold down the desired button of the original remote control until "SUCCESS" or "FAILED" appears in the display ① of the URC.
8. If in the LCD display ① "SUCCESS" appears (process successful), you can teach further buttons beginning with step 5. If "FAILED" appears (process unsuccessful) repeat the process in any case from step 5.
9. To stop the learn process any device button ④ can be pressed. If in the LCD display ① is shown "WAITING" then stopping can only be carried out with the EXIT ⑩⑥ button. After which the URC again returns to the "LEARN KEY" mode (see step 4).

Clear programmed button

1. Press the corresponding device button.
2. Hold down the SET button ③ for a little longer than 3 seconds.
3. With the ▲ or ▼ button ⑮ select "LEARNING" and confirm with the OK button ⑱. In the LCD display ❶ appears "LEARN KEY".
4. With the ▲ or ▼ button ⑮ select "DELETE KEY" and confirm with the OK button ⑱. In the LCD display ❶ appears "SELECT KEY".
5. Press the taught button that is to be deleted. In the LCD display ❶ appears "SURE DELET" (are you sure?).
6. Confirm the delete process with the OK button ⑱. In the LCD display ❶ appears "DELETED" and then again "SELECT KEY".
7. Repeat steps 5-6 to delete further buttons.
8. Press any device button ④ to end the mode.

Delete all of a device's programmed buttons

1. Hold down the SET button ③ for a little longer than 3 seconds.
2. With the ▲ or ▼ button ⑮ select "LEARNING" and confirm with the OK button ⑱. In the LCD display ❶ appears "LEARN KEY".
3. With the ▲ or ▼ button ⑮ select "DELETE DEV" (delete device) and confirm with the OK button ⑱. In the LCD display ❶ appears "SELECT DEV" (select device).
4. Select the device button ④ for the device whose taught button command you want to delete.
5. In the LCD display ❶ appears "SURE DELET". Confirm with the OK button ⑱. In the LCD display ❶ appears "DELETED" and then "SELECT DEV".
6. Repeat steps 4-5 if you also want to delete taught button commands of other devices.
7. The EXIT button ⑯ returns you to the previous status.

ⓘ Note:

The delete process can take several minutes depending on the number of taught commands.

Delete All programmed buttons

1. Hold down the SET button ③ for a little longer than 3 seconds.
2. With the ▲ or ▼ button ⑮ select "LEARNING" and confirm with the OK button ⑱. In the LCD display ❶ appears "LEARN KEY".
3. With the ▲ or ▼ button ⑮ select "DELETE ALL" and confirm with the OK button ⑱.
4. In the LCD display ❶ appears "SURE DELET". Confirm with the OK button ⑱. In the LCD display ❶ appears "DELETED" and then again "DELETE ALL".
5. With the EXIT button ⑯ you return to the previous status.

i Note:

The delete process can take a few minutes. Please be patient.

Programming Macros

With the MACRO function up to 16 button commands can be carried out with the press of a single button, that is to say, several previously saved control commands can be deleted with one MACRO button. There are 6 Macro memory slots available for you.

Macro programming overview:

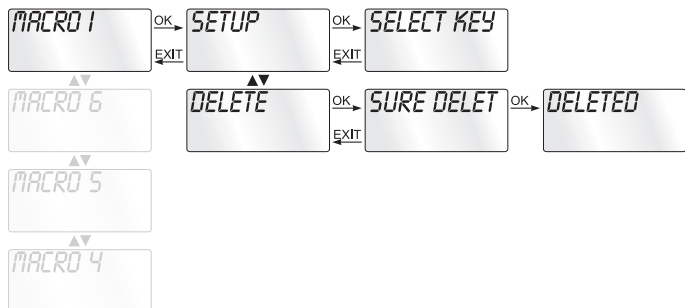

Macro programming (including PC)

For Macro programming proceed as follows:





1. Hold down the SET button **3** for a little longer than 3 seconds.
2. With the **▲** or **▼** button **15** select "MACRO" and confirm with the OK button **18**.
3. With the **▲** or **▼** button **15** select "MACRO1 to MACRO6" and confirm with the OK button **18**.
4. In the LCD display **1** appears "SET UP". Confirm with the OK button **18**.
5. In the LCD display **1** appears "SELECT KEY". Now press one after the other the desired buttons starting with a device button **4**. If the sequence does not begin with a device button **4** "ERROR KEY" (wrong button) appears in the LCD display **1** and then "SELECT KEY" again.
6. Save the entry with the OK button **18**. In the LCD display **1** appears "SUCCESS" and then the Macro selection mode again.
7. If you select a memory slot that is already occupied when you make the Macro programming selection (step 3) the device reacts to your setup attempt with the notice "MACRO HAS" (Macro occupied) in the LCD display **1**. After which "SET UP" will be shown again. Therefore you must first delete the memory slot before you can use it again. How that is done you will discover in one of the next sections under "Macro delete".
8. Repeat the process from step 3 to create further Macros.
9. With the EXIT button **16** you will move one level upwards in the menu.

i Tips:

1. A maximum of 16 button commands can be saved in a Macro. After entering the 16 button commands the Macro is automatically saved and in the LCD display appears "SUCCESS".
2. To exit the mode without saving press the EXIT button 16.
3. You can not save any Macros on a slot that is already occupied. If you want to programme a new Macro you must first delete the old Macro.
4. In the "SELECT KEY" mode you can only return to the previous status with the EXIT button 16.

Example You want to save a command chain in a Macro. We begin in the "SELECT KEY" mode.

Desired command chain: Switch on TV => switch to DVD
=> switch on DVD and playback

In the SELECT KEY mode, for this you enter the following button commands: TV =>  =>  => DVD/CD => 
=> 

Execute a Macro

To execute a preprogrammed Macro proceed as follows:

1. Press the MACRO button 22.
2. With the corresponding number button 9 access the desired Macro (1-6). Example If Macro 3 is to be executed first press the Macro button 22 and then the number button 3.

i Note:

If no Macro number button is pressed within 18 seconds or a Macro number button is pressed, for which no Macro has been programmed or another button is pressed then no Macro can be executed. In this case the background illumination blinks 4 times in rapid succession.

Macro deletion

To delete a preprogrammed Macro proceed as follows:

1. Hold down the SET button 3 for a little longer than 3 seconds.
2. With the ▲ or ▼ button 15 select "MACRO" and confirm with the OK button 18.
3. With the ▲ or ▼ button 15 select the desired Macro and confirm with the OK button 18. In the LCD display 1 appears "SET UP".
4. With the ▲ or ▼ button 15 select "DELETE" and confirm with the OK button 18.
5. In the LCD display 1 appears "SURE DELET" (are you sure?). Confirm the delete process with the OK button 18. In the LCD display 1 is shown the memory slot of the Macro that has just been deleted.
6. With the ▲ or ▼ button 15 you can delete other Macros. Then continue with step 3.

7. With the EXIT button 16 you will move one level upwards in the menu.

Favourites channel

Note:

This function is only available in the TV, SAT and CABLE modes and can not be used with other devices (it is also supported in AUX mode if TV, SAT or CABLE is programmed here).

With this function you can only show the stations, which you have summarized in favourite channels. Each of the 15 favourites channels can be assigned 6 stations, i.e. in one channel only sports stations, in the next all the news stations etc. When the child protection is activated the favourites of the device in question can not be retrieved.

Favourites programming overview:

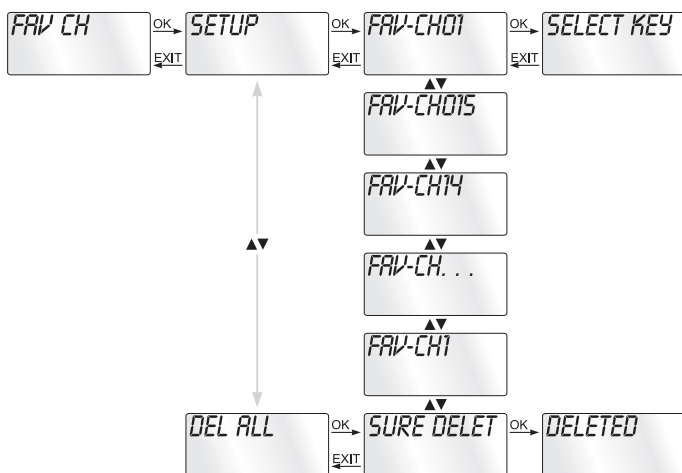

Programming FAV channels

Your favourite stations are saved as follows:

1. Press the desired device button 4 for the device to be programmed.
2. Hold down the SET button 3 for a little longer than 3 seconds.
3. With the ▲ or ▼ button 15 select "FAV CH" and confirm with the OK button 18.
4. In the LCD display 1 appears "SETUP". Confirm with the OK button 18. In the LCD display 1 appears "FAV- -CH1".
5. With the ▲ or ▼ button 15 select the desired FAV channel and confirm with the OK button 18. In the LCD display 1 appears "SELECT KEY".
6. Now enter with the number buttons 9 the first stations that you want to save in the respective FAV-CH (for two digit numbers first press the -/-- button 11). After you have pressed the sixth button of the station selection in FAV channel the setting will be automatically saved. In

the LCD display ❶ appears "SUCCESS" followed by the next FAV-CH. All buttons will be ignored except OK ❸, EXIT ❹, FAV.CH ❺, the number buttons ❻ and **-/--** ❼. Note: The URC saves the button presses. Therefore if you save two digit stations their max. count is reduced to 2 (1 x **-/--** + 2 number buttons = 3 pressed buttons per station).

7. Press the OK button ❸ to save the FAV-CH. In the LCD display ❶ appears "SUCCESS" followed by the next FAV-CH.
8. To exit this menu press repeatedly the EXIT button ❹ until the standard display appears in the LCD display ❶.
Note: A new programming of the FAV channels overwrites the old settings. The input of the channel numbers can vary according to the model and brand of the selected device.

Accessing FAV channel

To access the previously programmed favourite station press the FAV-CH button ❺.

The URC now accesses, one after the other, the programmed stations from the favourites channel with the lowest number. Press the FAV-CH button ❺ again and the stations from the next favourite channel up is accessed.

Delete All FAV channels

To delete all the FAV channels proceed as follows:

1. Hold down the SET button ❶ for a little longer than 3 seconds.
2. With the **▲** or **▼** button ❷ select "FAV CH" and confirm with the OK button ❸. In the LCD display ❶ appears "SETUP".
3. With the **▲** or **▼** button ❷ select "DEL ALL" and confirm with the OK button ❸. In the LCD display ❶ appears "SURE DELET" (are you sure?).
4. With the OK button ❸ you confirm the deletion of all programmed favourites channels. After which "DELETED" appears in the LCD display ❶ followed by "SETUP".
5. To exit this menu press repeatedly the EXIT button ❹ until the standard display appears in the LCD display ❶.

❶ **Tips:**

1. When the LCD display ❶ shows "SURE DELET" you can stop the delete with the EXIT button ❹.
2. Press any device button ❶ to exit the favourites delete mode.
3. Individual FAV channels cannot be deleted they can only be overwritten.

Volume control

Vol +/-, (Mute switching)

Press the "VOL+" button to increase the volume. With the "VOL -" button you reduce the volume. To mute the sound press the -button. A further press of this button turns the sound back on.

All devices use their own volume control, if available. If a video device, such as a VCR or DVD player, does not have its own volume control, the volume control of the television is automatically used.

Note:













1. The volume control does not function in the audio, PC and AUX modes.
2. The volume control does not function if the relevant device has its own volume and mute control functions (exceptions are possible).

Further volume control functions (except PC)

As mentioned above the volume controlling takes place automatically. If, however, you want to programme a device from another device proceed as follows:





Note:

The devices audio and PC do not have this function.

1. Hold down the SET button  for a little longer than 3 seconds.
2. With the  or  button  select "VPT SETUP" and confirm with the OK button . In the LCD display  appears "TO DEV" (to the device).
3. Now press the button for the device  (i.e. VCR), to which the volume command should be sent. After which appears "FROM DEV" (from device) in the LCD display  (the device, from which the command is sent).
4. Now press the button for the device  (i.e. TV), to which the command should be sent.
5. In the LCD display  appears "SUCCESS". The setting is saved. In the event of an error "ERROR" appears in the LCD display . After which "VPT SETUP" appears again.
6. With the EXIT button  you exit this mode.

Back to volume control

If you want to return to the basic volume control proceed as follows:

1. Press the desired device button (except PC).
2. Hold down the SET button  for a little longer than 3 seconds.
3. With the  or  button  select "BASIC VPT" and confirm with the OK button .

4. In the LCD display ❶ appears "SUCCESS".
5. With the EXIT button ❹ you exit the mode.

Additional functions

- ⇒ To operate one of the programmed devices with the URC first press the corresponding device button ❷.
- ⇒ Then point the URC to this device and press the desired button.
- ⇒ Put the number buttons ❸ exactly as you do with the original remote control. Before you make a two digit entry press the  button ❺.
- ⇒ With the **RECALL** button ❻ you can select the respectively last selected programme memory slot.
- ⇒ Press the **GUIDE** button ❼ to start the electronic programme guide of a device equipped with this function.
- ⇒ Press the **INFO** button ❽ to show current programme information from the target device.
- ⇒ Via the **MENU** button ❾ you access the dialogue for the setting of the respective target device.

All OFF

Note:

With the button  ALL OFF (all off) ❷ all devices can be automatically switched off. For this press the ALL OFF button ❷ twice within 2 seconds. This will only function under the following circumstances:

1. A visible connection exists between all the devices and the URC.
2. Automatic code search, brand code search and MACRO function are not active.
3. All target devices must be suitable for remote control switch off.

To automatically switch on all devices again press the button  ❷ once more twice within 2 seconds.







Automatic station redirecting

Note:

1. With this function all stations can be accessed in rapid succession without the necessity of manual redirection.
2. This function is only available for TV.
3. The function is then also for AUX available if a TV device is defined here.
4. Hold down the button CH+ or CH— **6** for 3 seconds. After which the Infrared symbol **30** blinks every 1.5 seconds and the next station is shown.
5. The remote control now continually sends every 1.5 seconds the command CH+ and/or CH— until a button is pressed. The background illumination (if activated) goes out briefly with each Infrared transmission.
6. Press any other button to end the automatic station redirecting.

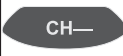
Alternative button allocation in teletext mode

If the remote control is in teletext mode (by pressing the button TTX ON/OFF **8**), the buttons CH+/CH— **6** and the play-back buttons serve as controllers for the teletext (TTX). After deactivation of the teletext the buttons revert back to their usual functions:

Button	Normal function	Function in TTX mode
	Start teletext	End teletext
	Shift forward 1 Programme slot	1 Page forward
	Shift back 1 Programme slot	1 Page backwards
	Start playback	Access index page
	Start record	Access last page
	Stop playback	Stop page search
	Stop playback	Stop automatic page change

Note:





The function is only available in the European TV mode and your TV must have a teletext module.

Alternative button allocation in PIP mode

i Note:

The PIP function (picture in picture) is only available in the TV mode. Your TV device must support this function.

You switch the PIP function on and/or off with the PIP button. If the remote control is in the PIP mode the following buttons serve as controllers for the PIP functions:

Button	Normal function	Function in PIP mode
	move up in the menu	PIP +
	move down in the menu	PIP -
	switch to AV	PIP source
	move left in the menu	PIP size
	move right in the menu	PIP position

Faults / Remedies

Your device does not react to the remote control.

- ⇒ Check the batteries. They must have enough voltage and be properly installed.
- ⇒ Firstly have you pressed the correct device button **4** for the desired target device?
- ⇒ Check to see that the correct code is programmed in for the target device (see section "Programming the remote control").

The remote control is transmitting the commands incorrectly.

- ⇒ Press the corresponding device button to set the remote control to the correct mode.
- ⇒ The batteries must have enough voltage and be properly installed.
- ⇒ It is possible that you are using the wrong code. Start the brand code search, the automatic code search or the direct code input (manual).

The remote control does not change the station on the device.

- ⇒ Press the corresponding device button ④ to set the remote control to the correct mode.
- ⇒ In the event that the original RC does not have a "-/-" button, change the programme with the CH+/- buttons ⑥ or the number buttons.
- ⇒ If this also does not work the child protection for this device could be activated.

Some of the remote control buttons do not function properly.

- ⇒ It is possible that your universal remote control does not have all of the functions that are on the device's original remote control.
- ⇒ It is possible that you have not programmed in the optimal code. Search for a code that supports more of the target device's functions.

The remote control stops reacting after a button is pressed.

- ⇒ The batteries must have enough voltage and be properly installed.
- ⇒ Point the remote control towards your device.

The LCD display shows nothing.

- ⇒ The batteries must have enough voltage and be properly installed.
- ⇒ The contrast could be set too low. Then increase the contrast setting.

Disposal



Do not dispose of the device in your normal domestic waste. This product is subject to the European directive 2002/96/EC.

Universal remote control

- Have the universal remote control or parts of it disposed of by a professional disposal company or by your communal disposal facility.
- Observe the currently applicable regulations. In case of doubt contact your disposal facility.

Batteries/rechargeable batteries

- Used batteries/rechargeable batteries may not be disposed of in household waste.
- Batteries can contain poisons which are damaging to the environment. Therefore, dispose of the batteries/rechargeable batteries in accordance with statutory regulations.
- Every consumer is legally obliged to surrender batteries/rechargeable batteries to a community collection centre in their district or to a dealer. The purpose of this obligation is to ensure that batteries are disposed of in a non-polluting manner.
- Only dispose of batteries when they are fully discharged.



Dispose of packaging materials in an environmentally responsible manner.

CE- Conformity



This device has been tested and approved regarding conformance with the fundamental requirements and other relevant regulations of the EMV Directive 2004/108/EC.

Importer

KOMPERNASS GMBH
BURGSTRASSE 21
44867 BOCHUM, GERMANY

www.kompernass.com

Technical data

Controllable devices 8

Dimensions

L x W x H: 225 x 56 x 28 mm

Weight : 120 g (without batteries)

Laser: Laser class 1

Power supply

Batteries: 2 x 1.5 V, type AAA/LR03 (micro)
(Batteries not supplied)

Important Warranty Notices

You receive a 3-year warranty for this device as of the purchase date. Should you have grounds for complaint in spite of our high quality standards, please contact our Service Hotline. In the event that processing of your complaint is not possible by telephone here you will receive

- a processing number (RMA number) as well as
- an address to which you can send your device for repair under warranty.

In the case of a mail-in shipment, please enclose a copy of the purchase receipt (sales slip). The device must be securely packed and the RMA number clearly visible. Products sent in without the RMA number cannot be processed.

i Note: The warranty provisions cover only material or factory defects. The warranty is not valid;

- to parts subject to wear and tear
- for damage to breakable parts, such as switches or rechargeable batteries.

This product is for private use only and is not intended for commercial use. The warranty is void in the case of abusive and improper handling, use of force and internal tampering not carried out by our authorized service branch. Your statutory warranty claims are not restricted by this warranty.

Completely fill our this section and enclose with the appliance!



UNIVERSAL REMOTE CONTROL
KH 2155

**In order to guarantee a cost free
repair procedure please get in
touch with the service hotline.
Make sure you have your sales
slip handy.**

Sender, please write clearly:

Last name: _____

First name: _____

Street: _____

Postcode/Place: _____

Country: _____

Telephone: _____

Date/Signature: _____

Warranty

GB

DES Ltd

Tel.: 0870/787-6177

Fax: 0870/787-6168

e-mail: support.uk@kompernass.com

IE

Kompernass Service Ireland

Tel: 1850 930 412 (0,082 EUR/Min.)

Standard call rates apply. Mobile operators may vary.

e-mail: support.ie@kompernass.com

www.mysilvercrest.de

